

Article number: 208202130MF

Description: E+G horizontal clamps  
GN 820.2-130-MF

## Measures

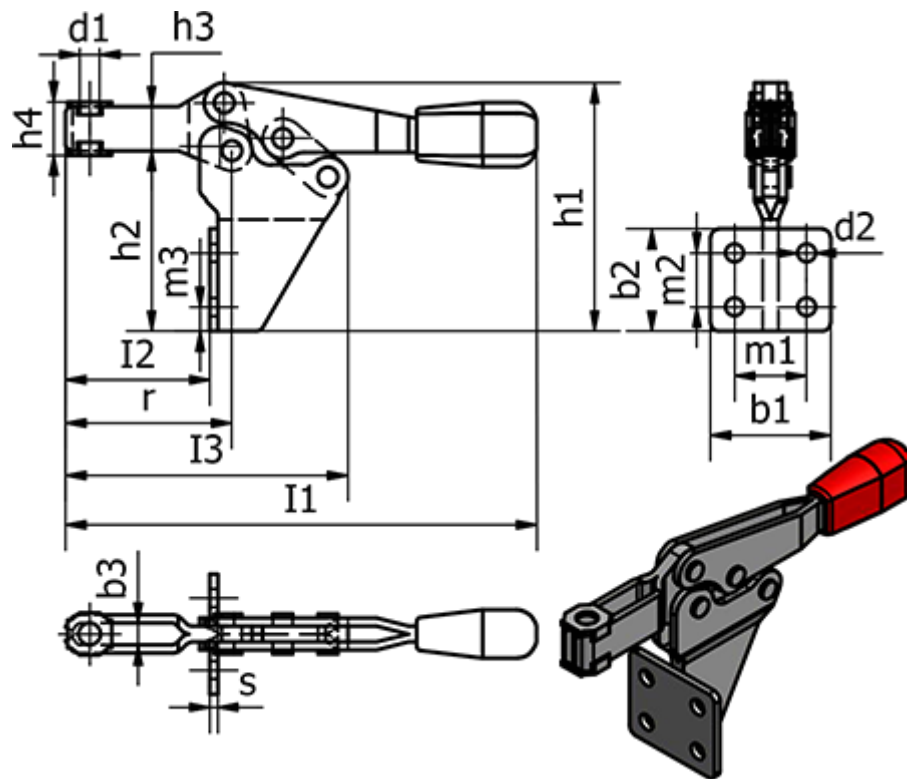

b1 = 39	h4 = 27	r = 61
b2 = 35	Holding force in N = 1000	s = 2.5
b3 = 6.5	l1 = 170	Wight (g) = 240
d1 = M6	l2 = 45	
d2 = 5.5	l3 = 95	
h1 = 85	m1 = 26	
h2 = 58.5	m2 = 22	
h3 = 14	m3 = 6.5	